

NEITZ

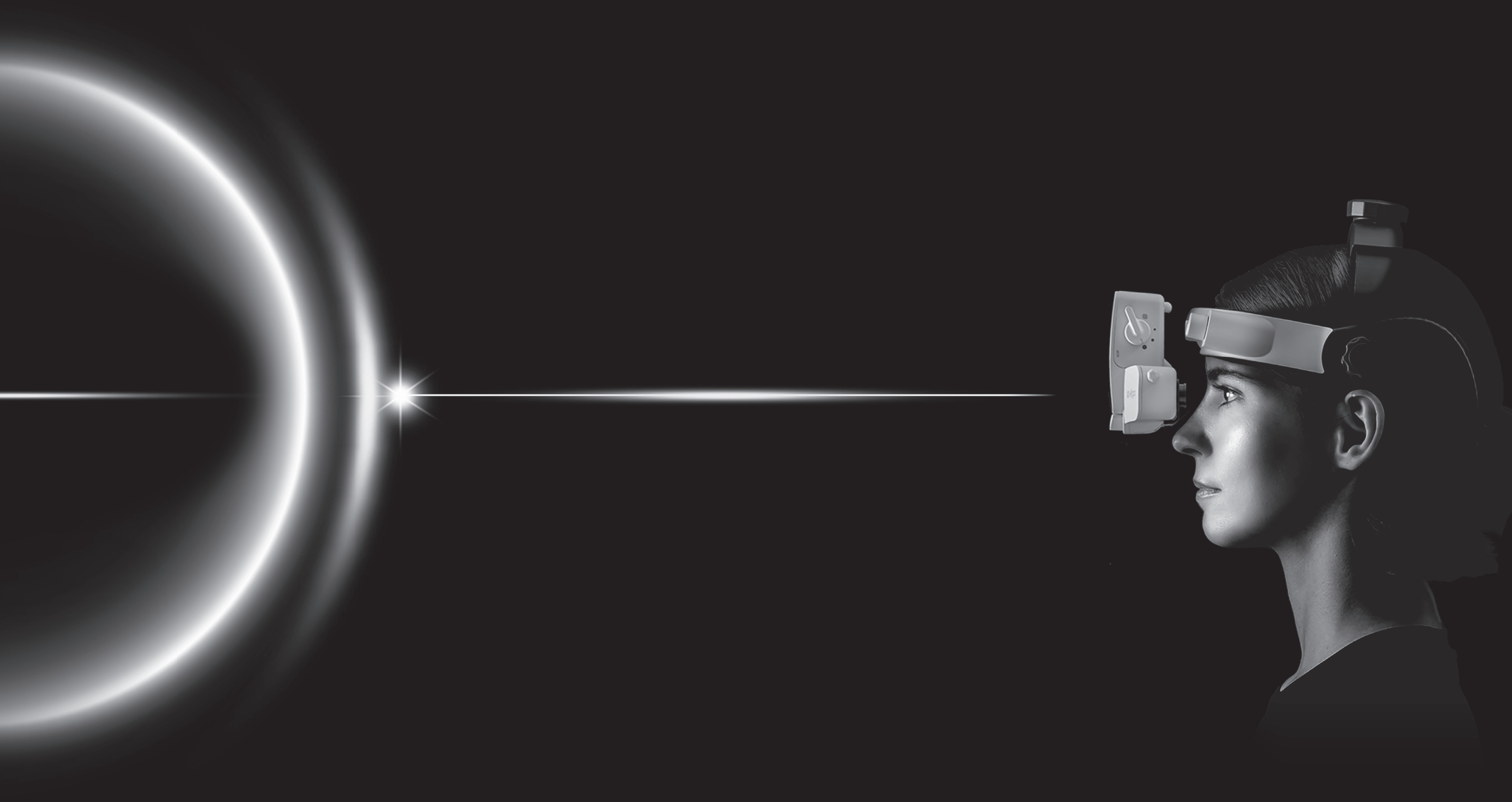

IO-vega

See deeper. See clearer.



See deeper. See clearer.

A New Horizon of Binocular Indirect Ophthalmoscope.

Aiming to provide better ophthalmic care for both doctors and patients. NEITZ proudly introduces the newly developed Binocular Indirect Ophthalmoscope, IO-Vega.

In addition to its exceptional optical performance that captures the fundus with remarkable clarity and precision, it achieves a compact and lightweight design with simplified operation, pursuing user friendliness at the highest level. The IO-Vega makes it easier than ever to deliver reliable, high quality ophthalmic care.



From History to Philosophy

**The optical DNA NEITZ inherits.
It began with the aspiration
and passion of an ophthalmologist.**

**The direct ophthalmoscope, invented in 1913.
This is the origin of Neitz.**

The origin of Neitz Instruments Co., Ltd. can be traced back to 1913. The ophthalmologist Dr. Ryuichi Naito believed that innovative equipment was essential for the advancement of ophthalmic medicine. While practicing ophthalmology, Dr. Naito developed Japan's first electric ophthalmoscope. In 1937, its improved version "Naito Electric Ophthalmoscope" was released and became widely adopted as the standard supporting medical practice. "If the ideal ophthalmic equipment does not exist, I will create it with my own hands." This journey, which began with an ophthalmologist's lofty aspirations and passion, forms the foundation of Neitz today.



NEITZ Ophthalmoscope - Assembled in 1953.

**Birth of the brand name NEITZ.
It is a tribute to two pioneers.**

In 1948, Dr. Akira Naito (a graduate of Keio University School of Medicine), an ophthalmologist who carried on his father's aspirations, established the Naito Ophthalmic Instrument Laboratory. This is the predecessor of NEITZ. He imbued the brand name "NEITZ" with a profound tribute to his father and founder "NAITO" and to the German scientist and physician "Helmholtz," the inventor of the ophthalmoscope. Just as our products were born from the founder's aspirations, NEITZ's enduring mission remains unchanged: to embody the aspirations of those on the medical fields and deliver optimal solutions to the forefront of healthcare, no matter how times may change.

**IO-Vega illuminates the future of ophthalmic
medicine. The culmination of knowledge and skill
passed down through centuries.**

We, inheriting a lineage spanning over a century since 1913, have continually refined our techniques alongside the advancement of ophthalmic medicine. In 2013, NEITZ relocated its research and development and manufacturing base to Nagano. At our newly established Southern Studio, we continue to pursue the challenge of seamlessly integrating our renowned precision craftsmanship with contemporary design. The culmination of this effort is the Binocular Indirect Ophthalmoscope IO-Vega. Like the Vega (Alpha Lyrae), destined to become the North Star in the distant future, we aspire this device will serve as a guiding light illuminating the future of medicine.



The star symbol placed above the "e" in the product logo symbolizes Vega, which will become the North Star in approximately 12,000 years. It is aligned at the same angle due to the Earth's rotational axis being tilted 23.4 degrees.

An Unwavering Pursuit of Optical Excellence. Design Precision & Manufacturing Technology & Alignment Expertise.

Design Precision - A Philosophy Devoted to Mastering Light

The foundation of IO-Vega's design philosophy begins with a single question: How we should guide the light? In our lens design, optical aberrations are corrected by precisely optimized lens geometry, achieving higher image quality with exceptional clarity. A special multilayer anti-reflective coating - engineered with wavelength-selective absorption - suppresses unwanted reflections on the lens surface, preventing ghosting and flare, enhancing light transmittance, and allowing only the "true light" essential for diagnosis to pass through.

Anti-reflective treatment is also applied to the lens barrel interior, refining the optical purity of the entire system to its utmost limit and supporting precise diagnosis without overlooking even subtle abnormalities. IO-Vega also features a wide dynamic range of illumination - from extremely low brightness (below 10 lx) to high brightness (up to 1,700 lx). By adopting a PWM lighting circuit, it achieves smooth, flicker-free dimming even at low illumination levels. IO-Vega delivers light the users need while minimizing patient burden.

Manufacturing Technology - Refining the Precision to the Highest

The basis supporting IO-Vega's performance lies in carefully selected materials and highly precise manufacturing techniques. Streamlining the overall structure and enhancing machining accuracy, we rigorously choose materials according to their optimal application including optical glass, aluminum, magnesium, wear resistant stainless steel, and advanced engineering plastics.

By use of CNC precision machining and ultra fine mechanical processing, tolerances are controlled down to tens of microns. Only components that satisfy these strict standards enter our tolerance managed production process. Each unit is meticulously assembled by skilled craftsmen who take over the expertise cultivated over many years. Every step in our manufacturing technology represents a chain of refined techniques, forming an essential element that crystallizes IO-Vega's optical performance at its highest level.

High Precision Alignment - The Final Process That Builds Trust

The final adjustment and inspection processes are what ultimately determine the level of the completion and quality of IO-Vega. Using dedicated alignment fixtures, our engineers perform ultra precise adjustments that craft the high quality "visibility" essential for clinical use. By meticulous visual axis tuning and micro-level optical axis positioning, a stable and reliable illumination field is secured. This alignment expertise - refined through years of accumulated experience - ensures long term performance and enduring reliability. In the final inspection, our specialists rely on their exceptional observational senses, capable of detecting subtle fluctuations in light or slight "breathing" inconsistencies between components that numerical values cannot capture.

While providing feedback to the manufacturing team, they employ sensitivities that cannot be expressed in manuals or measured by instruments - serving as the last line of defense that protects our uncompromising quality.

Behind IO-Vega's unwavering reliability stands the dedication of craftsmen who do not accept anything less than perfection.



Pursuit of Clarity

Patient Friendly



Designed for Doctors. Gentle for Patients. Shaping the Ideal of the Ophthalmic Care.

A Design That Brings Comfort and Reassurance to Patients

From the patient's perspective, IO-Vega features a bright platinum gray body with a subdued, low gloss finish. This color choice conveys cleanliness and softness, helping ease tension during examination. To address feedback from physicians - particularly the need for gentler illumination during fundus observation in newborns and young children - IO-Vega enables examinations at extremely low illumination levels below 10 lx to minimize pupil constriction. For situations requiring more precise diagnosis, IO-Vega also supports high brightness illumination up to 1,700 lx. This wide illumination range allows examinations to be tailored to each patient's individual needs.



Flip-up Mechanism That Never Interrupts Communication

We believe that smooth communication with the patient is an essential function during examination. To support natural interaction throughout the diagnostic process, IO-Vega is equipped with a proprietary flip up mechanism. The optical unit positioned in front of the eyes can be smoothly lifted with one hand, thanks to its precision engineered hinge structure, instantly clearing the field of view. This allows doctors to maintain eye contact, observe facial expressions, and speak with consideration—all without removing the device.



Ball Joint Mechanism That Minimizes Patient Waiting Time

We developed an original ball joint mechanism that enables doctors to quickly and easily achieve their optimal field of view. By incorporating a movable joint with ball bearings, the optical unit can be smoothly adjusted up to ± 3 degrees in all directions using the control knob, allowing for precise fine tuning. This makes it possible to instantly align the eyepiece position to the ideal spot, accommodating individual differences in head shape and facial structure. As a result, the time from putting on the device to beginning the examination is significantly reduced - allowing doctors to face the patient without delay.

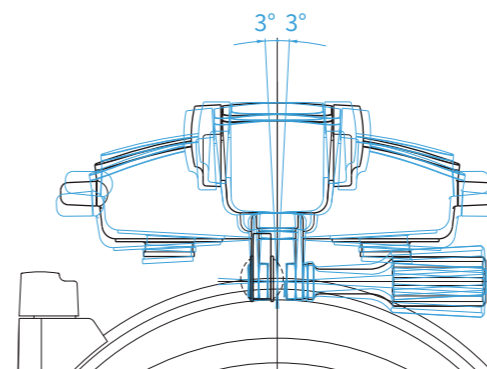

Lightweight, Well-Balanced Design for Lasting Comfort

Weighing approximately 460 g, IO-Vega achieves one of the lightest designs in its class of binocular indirect ophthalmoscopes. By re-examining the structure from the ground up, minimizing the number of components, and adopting lightweight materials such as magnesium alloy, significant weight reduction was achieved. To prevent front back imbalance during use, the device is engineered with careful attention to overall weight distribution. By distributing the mass of the optical unit and the rear power unit appropriately and positioning the center of gravity near the top of the head, IO-Vega provides a comfortable fit that feels natural throughout use. This balanced weight design helps doctors maintain optimal condition and stay focused during examinations.

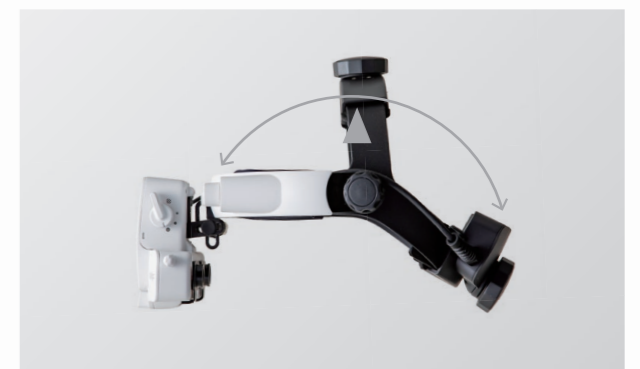



Technical Details



Headband

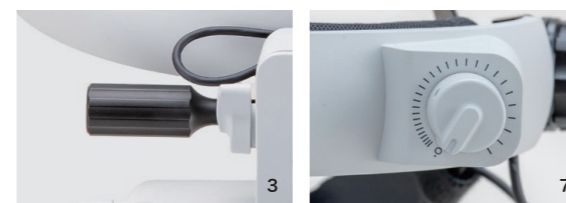

- 1 Headband**
A flexible, lightweight frame that supports the entire device.

- 2 Adjustment Knobs**
Located at the top and back of the head, these knobs allow fine adjustment of overall fit.

- 3 Clamp Bolt**
Used to adjust the eyepiece position. The knob can be moved smoothly in all four directions to set the optimal field of view.

- 4 Overband**
Used to raise and lower the optical unit.

- 5 Overband fixation knobs**
Locks the over band in the flipped-up position, allowing natural communication while observing the patient's expressions.

- 6 Battery housing**
Supports charging via a USB Type C cable.

- 7 Output switch**
A rotary power switch that enables smooth adjustment of LED brightness.

Main unit

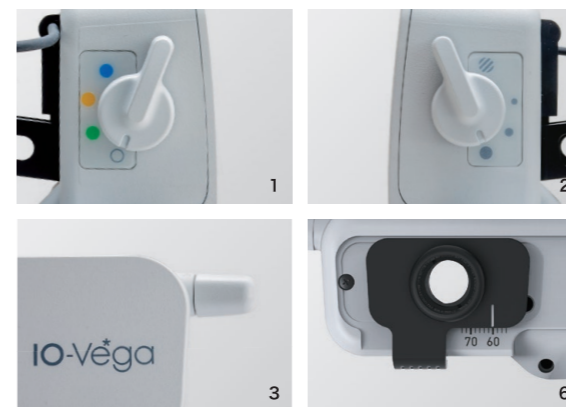
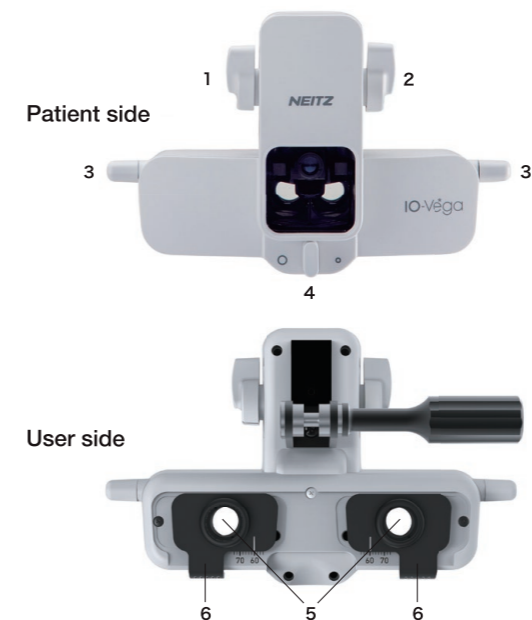

- 1 Filter selection lever**
Allows switching among four filters to match patient characteristics and diagnostic needs.
 - UV Filter
Blocks ultraviolet light and works with a high color rendering (Ra 90+) white LED to enable safe, natural color fundus observation.
 - Red Free Filter
Removes red wavelengths to enhance the contrast of retinal blood vessels and the nerve fiber layer; suitable for detailed examinations of glaucoma and diabetic retinopathy.
 - Yellow Filter
Cuts blue light to reduce glare and visual discomfort, making it effective for observing newborns and young children who are sensitive to light.
 - Cobalt Blue Filter
Emphasizes blue light for fluorescein based fluorescence observation. Useful not only for anterior segment evaluation—such as corneal epithelial disorders and tear film assessment—but also for fundus examinations utilizing fluorescein staining.

- 2 Aperture selection knob**
Allows switching among four illumination field diameters: large, medium, small, and diffuser.

- 3 Illumination angle adjusters**
Adjust the illumination angle. Positioned on both sides and mechanically linked for synchronized movement.

- 4 Observation optical axis adjuster**
Adjusts the observation angle. Slide the lever to the left for large pupils and to the right for small pupils.

- 5 Eyepiece**
Equipped with built in corrective lenses equivalent to +2 diopters.

- 6 PD Adjusting Slides**
Enables fine adjustment of interpupillary distance by sliding the mechanism left or right.



Smart Charging

A Compact and Lightweight 4 Way Charging System for Any Clinical Style or Space



RC4 Desktop Charger

The compact design makes efficient use of examination desks and clinical workspaces. It securely holds the device while automatically and wirelessly charging the main unit battery, providing a clean and uncluttered appearance.



RC5 Wall mounted Charger

Designed to maximize clinical space by utilizing wall surfaces. The charger maintains the device in a fixed, organized position without obstructing workflow. It automatically and wirelessly charges the main unit battery simply by placing the device on the mount.



Direct USB Charging (Main Unit)

The battery pack can be charged while it remains attached to the main unit. This eliminates the need to carry a charger, making on-the-go charging simple and convenient.



Direct USB Charging (Spare Battery)

The spare battery pack can be charged directly via USB. Keeping a charged spare battery on hand ensures extended operation even if the main unit's battery runs low during off-site use.

Reliable Power Supply—Whether in the Clinic or on the Move

IO-Vega has a 4-way charging system to support both stationary use in examination rooms and mobile use during home or field visits.

Users can choose from 4 charging methods:

1. **Desktop Charger,**
2. **Wall mounted Charger,**
3. **Direct charging of the main unit, and**
4. **Direct charging of a spare battery.**

The USB Type C-based charging system is compact and lightweight, offering excellent portability. As both the main unit and the spare battery can be charged directly, no need to carry a charger when using the device outside the clinic. This flexible system ensures reliable power not only in examination rooms but also in environments with limited space - providing high mobility for home visits and other off-site examinations.

Charge Monitoring System That Ensures Both Safety and Responsiveness

The battery housing used for the Desktop Charger and Wall mounted Charger continuously monitors charging status during downtime, keeping IO-Vega optimal and always ready to use. During charging, 4 built-in safety check functions operate to ensure safe and reliable performance.

1. **Current Monitoring**
Prevents overcurrent and keeps stable charging.
2. **Voltage Monitoring**
Detects overvoltage and undervoltage to protect the battery.
3. **Temperature Monitoring**
Prevents overheating and contributes to extended device lifespan.
4. **Magnetic Detection Tester**
Automatically recognizes correct placement on the stand, ensuring a reliable charge start.

Battery pack



- 1 **Battery housing**
Supports charging via a USB Type C cable.
- 2 **Battery pack**
A removable unit that can be charged independently.
- 3 **Charge lamp**
Lights bright green during charging and switches to dim green when charging is complete.
- 4 **Battery level indicators**
Displays the battery level using three LED lamps.

Optional Accessories



TM2 Teaching Mirror

The Teaching Mirror is an auxiliary device that enables another doctor or researcher to observe the same fundus view simultaneously while the primary doctor uses the binocular indirect ophthalmoscope. Conventional teaching mirrors provided only a left-right optical axis, requiring the observer to lower their posture to align their eye level with that of the ophthalmoscope. The newly developed Teaching Mirror resolves this issue. Equipped with a 180-degree vertical rotation mechanism, it allows observers to view the same image without bending down providing a clear fundus view even from upward or diagonally elevated positions. The large mirror it can reflect the entire fundus image. (Patent pending)



VCI Voyage Case

The Voyage Case is ideal for carrying IO-Vega during home visits or off-site examinations. It features a molded inner tray designed to fit the main unit and accessories securely, providing excellent shock absorption to reduce vibration during transport. The outer fabric is water repellent, offering protection against light rain. With the dedicated space for a laptop and small items, the case is thoughtfully designed for convenience and ease of use in every detail.

1 Main Compartment	A full-open design for taking in and out IO-Vega easily. A molded tray made of expanded polyethylene securely fits the main unit and accessories, absorbing shock during transport.
2 Accessory Pocket	A soft, protective pocket suitable for handheld medical devices, smartphones, mobile batteries, and other small items. The plush moquette fabric gently cushions the contents.
3 PC Compartment	A large compartment that accommodates laptops up to 17 inches. Thick, shock resistant padding protects the PC, while all around cushioning reinforces the corners for added safety.



IOC2 Carrying Case

The semi hard carrying case offers outstanding durability. It securely holds the main unit and accessories in place, ensuring safe transport. It also serves as an ideal storage case for daily use.



20D Aspherical Lens

The 20-diopter aspherical lens is engineered to support highly precise examinations. It minimizes distortion across the entire field of view, delivering sharp and clear images to the very edges.



SPP Cushion Pads

These pads provide comfortable contact with the forehead and head. Available in four colors, they can be replaced easily, allowing each doctor to use their own dedicated pad when sharing the IO-Vega.

Specifications

Light Source	High color-rendering white LED CRI Ra: 90(min)/R9:80(min), 3000K(typ)
PD	Eyeieces can be positioned to match the user's interpupillary distance.
Adjustment	PD range: 52-73 mm
Aperture Switching	Four-step switching - Ø65, Ø50, Ø19 mm, and diffuser (at 500 mm)
Filter Switching	Four optical filters — UV, red free, yellow, and cobalt blue
Illumination Angle	Illumination angle can be adjusted vertically by turning the stepless adjustment knob.
Observation Optical Axis	Observation angle can be adjusted by sliding the knob left or right.
Eyepiece	+2D
Brightness Control	Volume switch with ON/OFF click; includes a half click at the midpoint.
Illuminance	Max: 1100 lx / Min: <10 lx (at 500 mm), Max: 1700 lx / Min: 16 lx (at 400 mm)
Continuous	Maximum brightness: approx. 3 hours. Medium brightness: approx. 8 hours.
Illumination Time	Practical use: approx. 10 hours. (Based on internal standards.)
Battery pack	Removable from the battery housing. Built in lithium-ion rechargeable battery (Rated: 3.7 V, 800 mAh, 2.96 Wh)
Battery Level Indicators	3 LED indicators on the battery housing: 3 green LEDs: High charge. 2 green LEDs: Medium charge, 1 green LED: Low charge, 1 orange LED: Very low charge
Charging Methods	USB Type C charging supported. Four methods available: - Battery pack only, - Via battery housing, - Via Desktop Charger, - Via Wall Mounted Charger.
Charging Time	Approx. 2 hours
Charging Indicator	Bright green: Charging. Dim green: Fully charged.
Power Consumption	Discharging: 1.0 W. Charging: 6 VA.
Min. Pupil Diameter	φ2mm
Headband Circumference	520 to 640mm
Dimensions	Main unit: 123 × 94 × 44 mm (excluding protrusions and headband)
Weight	Main unit: Approx. 460 g

Set Components

	Main unit	Battery pack set	User's Manual	Lens cloth	Pouch (small)	Carrying case	Desktop Charger	Wall mounted Charger	Voyage case	Teaching mirror
IO-Vega Basic Set	○	○	○	○	○	—	—	—	—	—
Set-C (for Carry)	○	○	○	○	○	○	—	—	—	—
Set-D (for Desk)	○	○	○	○	○	—	○	—	—	—
Set-W (for Wall)	○	○	○	○	○	—	—	○	—	—
Set-V (for Voyage)	○	○	○	○	○	—	—	—	○	—
Set-S (for Students)	○	○	○	○	○	—	—	—	○	○



Optional Accessories

- 20D Aspherical lens
- Desktop charger
- Wall mounted charger
- Teaching mirror
- Spare battery pack
- Forehead pad
- Cushion pads (2 in 1 package) Black, Blue, Pink, Orange
- Carrying case
- Voyage case
- Detachment chart (Available for download on our website)

IO-Vega

Visit Our Special Website!

